

# D3O® CP1 COMPACT L1

D3O® CP1 COMPACT

**D3O uses patented, patent-pending and proprietary technologies to make rate-sensitive, soft, flexible materials with high shock absorbing properties.**

The D3O® CP1 Compact L1 chest protector features a low-profile, optimised material and TriVent geometry combination to provide maximum ventilation and protection for the 2-wheel market. Its winged, tapered design offers additional rib protection and discreet integration into jackets.

The CP1 Compact is ideal for those wanting a smaller pad due to smaller chest size or the need for increased freedom of movement.

## PRODUCT FEATURES

- D3O® patented technology
- Certified to exceed the performance requirements of EN 1621-3:2018 Level 1, including optional cold test at -10°C
- UKCA Certified
- Ventilation offering superior breathability
- Available in full chest
- Winged design
- Type A coverage

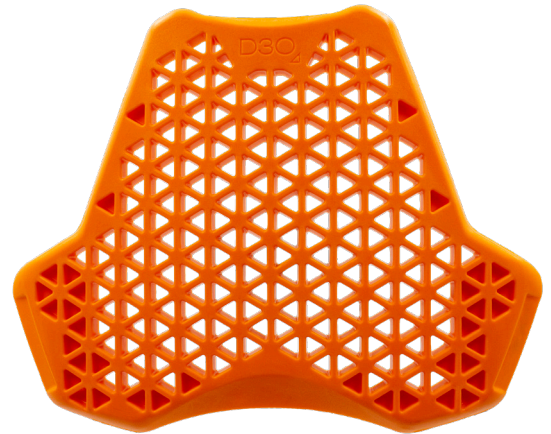

### PAD INTEGRATION EXAMPLE



### COMPACT FORM FACTOR



### SUPERIOR BREATHABILITY

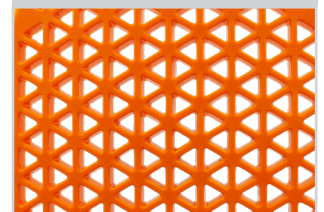

### WINGED DESIGN

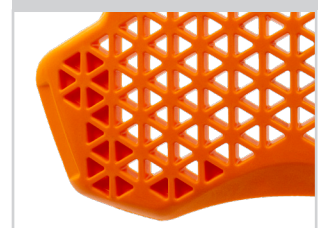

©2021 Design Blue Limited. All rights reserved.

Values shown represent typical product characteristics. For full details including material properties and product tolerances, please request SOQ document from D3O representative. The information provided is not intended to and does not create any warranties, expressed or implied, including any warranty of merchantability of fitness for a particular purpose. In accordance with the Company's policy of continuous improvement, D3O reserves the right to apply such improvements to its products and materials without notice. This data sheet shall not be reproduced or amended without the written consent of Design Blue Limited.

For more information on the D3O® CP1 COMPACT L1, please contact your D3O Business Development Manager

TRUSTED IMPACT PROTECTION™

# D30® CP1 COMPACT L1

FULL

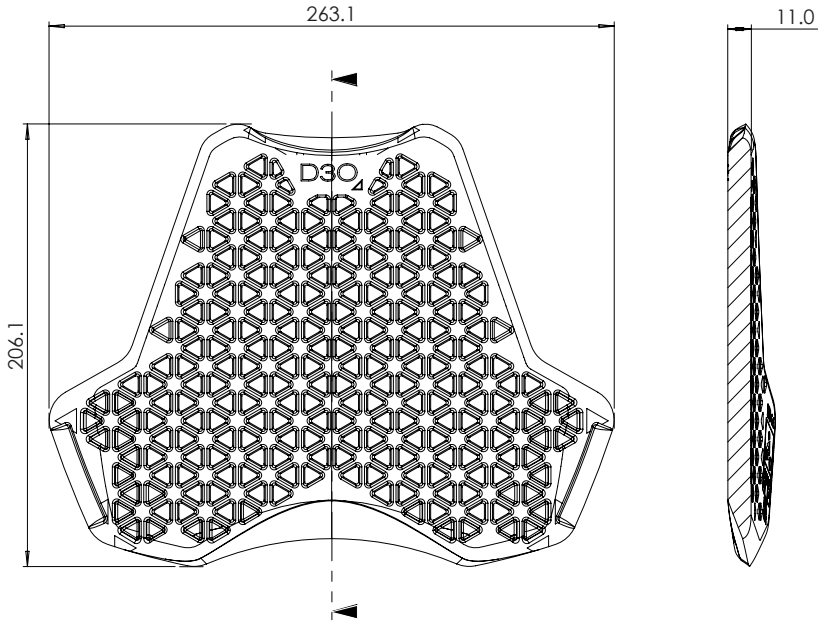

## D30® CP1 Compact L1 - Product details

Product Name	D30® CP1 Compact L1 F
Product Code	14251
Dimensions (mm)	263 x 206
Thickness (mm)	11
Weight (g)	140

## D30® CP1 Compact L1 - Tested to EN 1621-3:2018 Level 1



©2021 Design Blue Limited. All rights reserved.

Values shown represent typical product characteristics. For full details including material properties and product tolerances, please request SOQ document from D30 representative. The information provided is not intended to and does not create any warranties, expressed or implied, including any warranty of merchantability of fitness for a particular purpose. In accordance with the Company's policy of continuous improvement, D30 reserves the right to apply such improvements to its products and materials without notice. This data sheet shall not be reproduced or amended without the written consent of Design Blue Limited.

TRUSTED IMPACT PROTECTION™